



# System reliability upper bound assessment for health-aware control of complex systems



Fourth European Conference  
of Prognostics and Health  
Management Society  
3-6 July 2018, Utrecht,  
The Netherlands

Jean C. Salazar  
Universitat Politècnica de Catalunya  
jean.salazar@upc.edu

Ramon Sarrate  
Universitat Politècnica de Catalunya  
ramon.sarrate@upc.edu

Fatiha Nejari  
Universitat Politècnica de Catalunya  
fatiha.nejjari@upc.edu

Student Poster

## Research Objective

This work investigates the possibility of using an approximate computation of the system reliability into a HAC scheme. Specifically, an upper bound of the system reliability will be computed in order to overcome the computational problem of determining the exact system reliability of a complex system and its integration into a health-aware control strategy [1].

## Expected Contributions

- A HAC scheme for complex systems based on the system reliability upper bound computation.
- A reduction of the system reliability computation cost by using the upper bound approximation.

## Research Details

### MPC scheme tuning methodology

1. Enumerate the minimal path sets  $P_j$
2. Compute the structure function

$$\Phi_p(X) = 1 - \prod_{j=1}^s \left( 1 - \prod_{i \in P_j} X_i \right)$$

3. Compute the system reliability upper bound

$$R_s^{up} = 1 - \prod_{j=1}^s \left( 1 - \prod_{i \in P_j} R_i \right)$$

4. Compute the components reliability

$$R_i(t) = e^{-\int_0^t \lambda_i(v) dv} \quad \lambda_i(t) = \lambda_i^0 \left( 1 + \beta_i \int_0^t |u_i(v)| dv \right)$$

5. Compute the MPC weights based on a normalized component Birnbaum's measure

$$I_{B,i}^{up} = \frac{\partial R_s^{up}}{\partial R_i} \quad \rho(k) = \hat{I}_B^{up}(k)$$

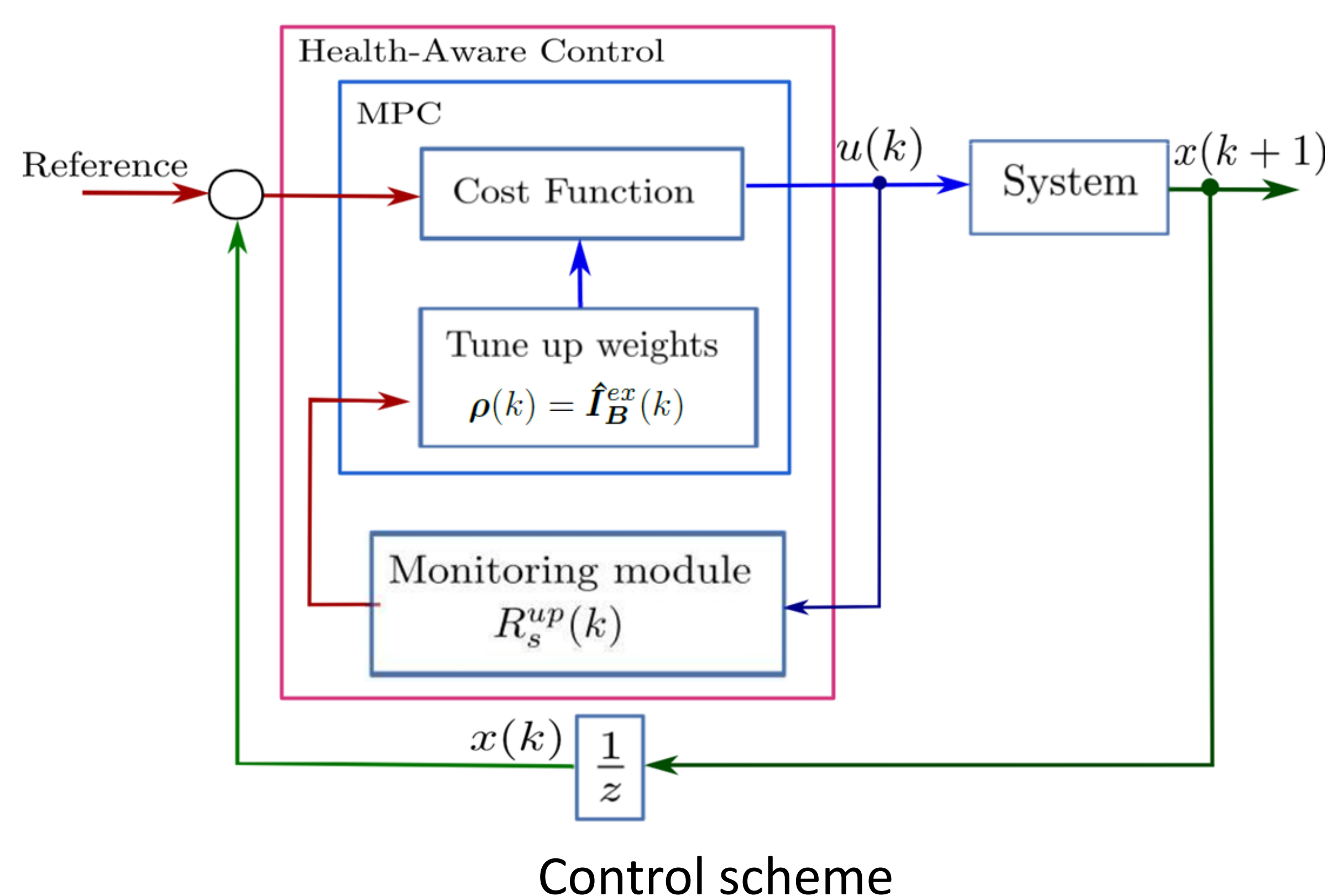

## State of Research

Even with the approximate approach, better system reliability results than in the nominal case are obtained.

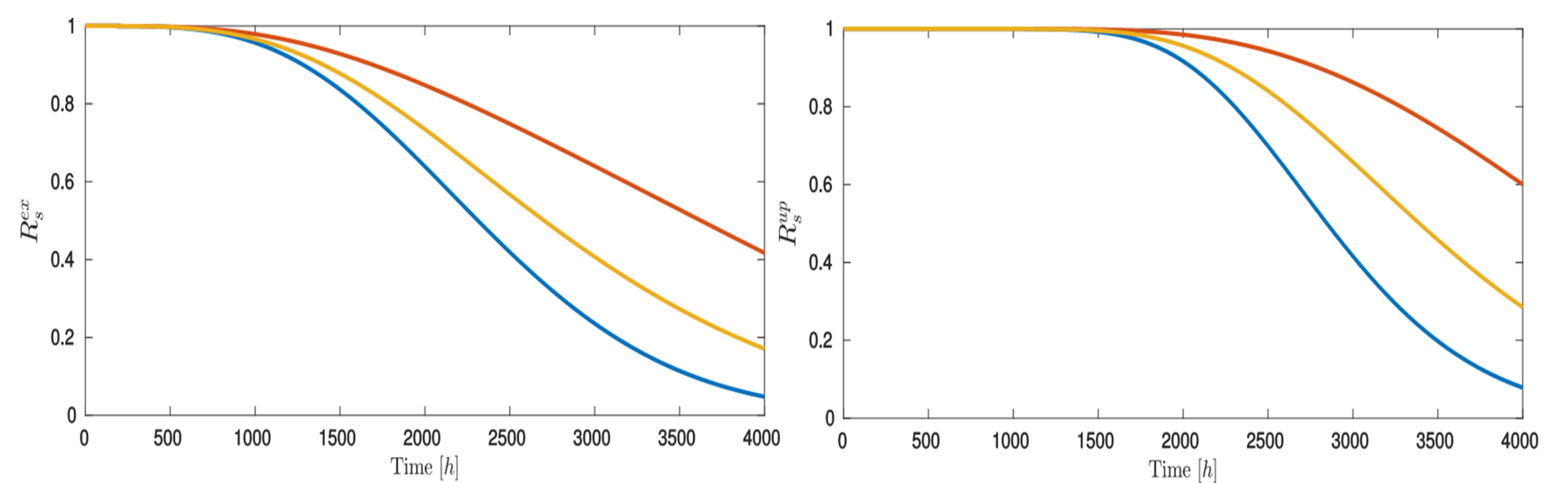

Procedure	Exact [s]	Upper bound [s]
System reliability	0.0981	0.0608
Birnbaum's measure	0.5060	0.2329
TOTAL	0.6041	0.2937

Computation times

## Next Steps

- These results encourage us to do further research in the domain of HAC for complex systems.
- Investigate the use of a system reliability lower bound approximation to implement the HAC methodology.

## Comparative study

Three case studies: **exact approach** ( $\rho(k) = \hat{I}_B^{ex}(k)$ ), **approximate approach** ( $\rho(k) = \hat{I}_B^{up}(k)$ ), **nominal approach** ( $\rho = 1$ , no reliability feedback).

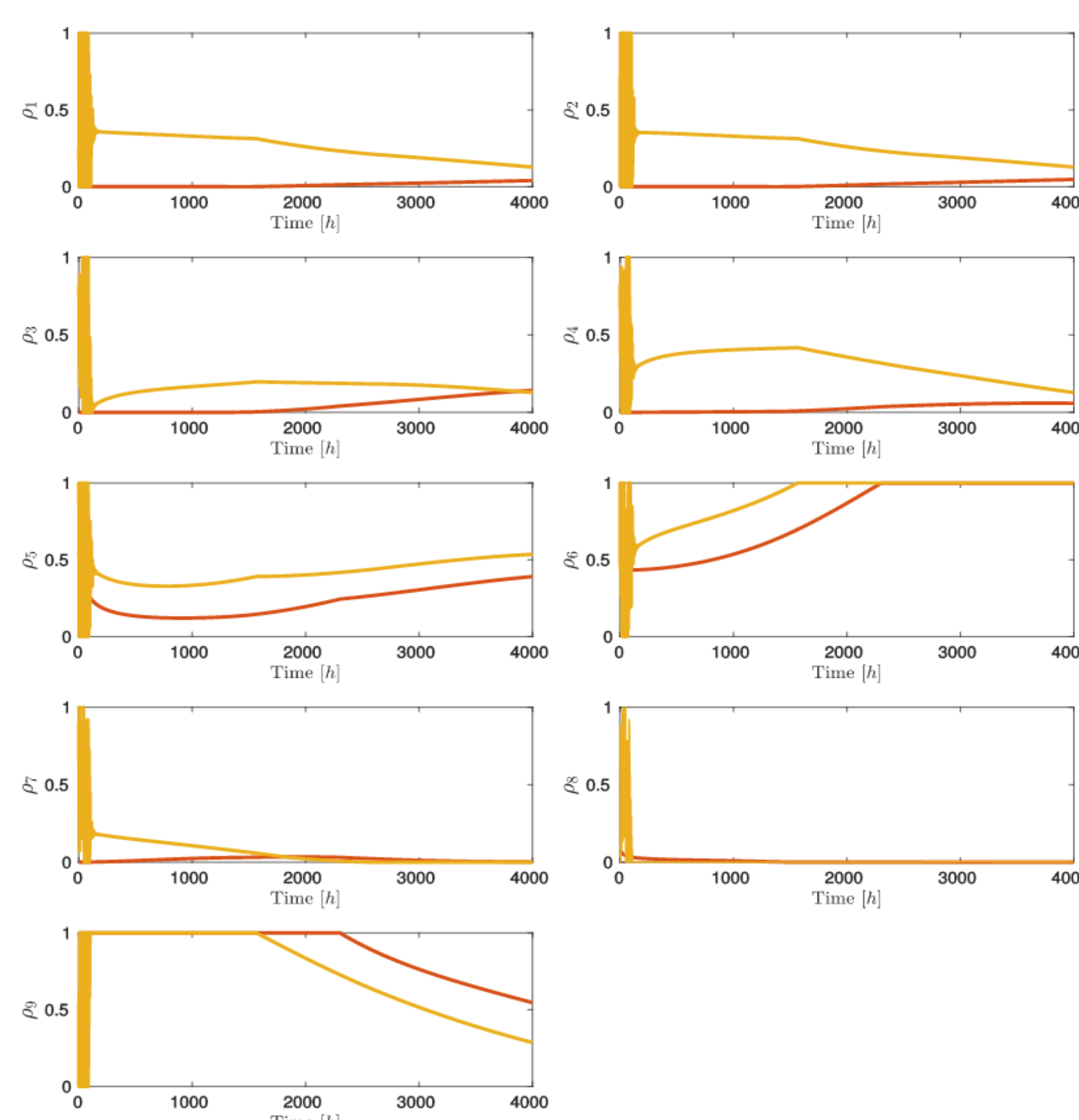
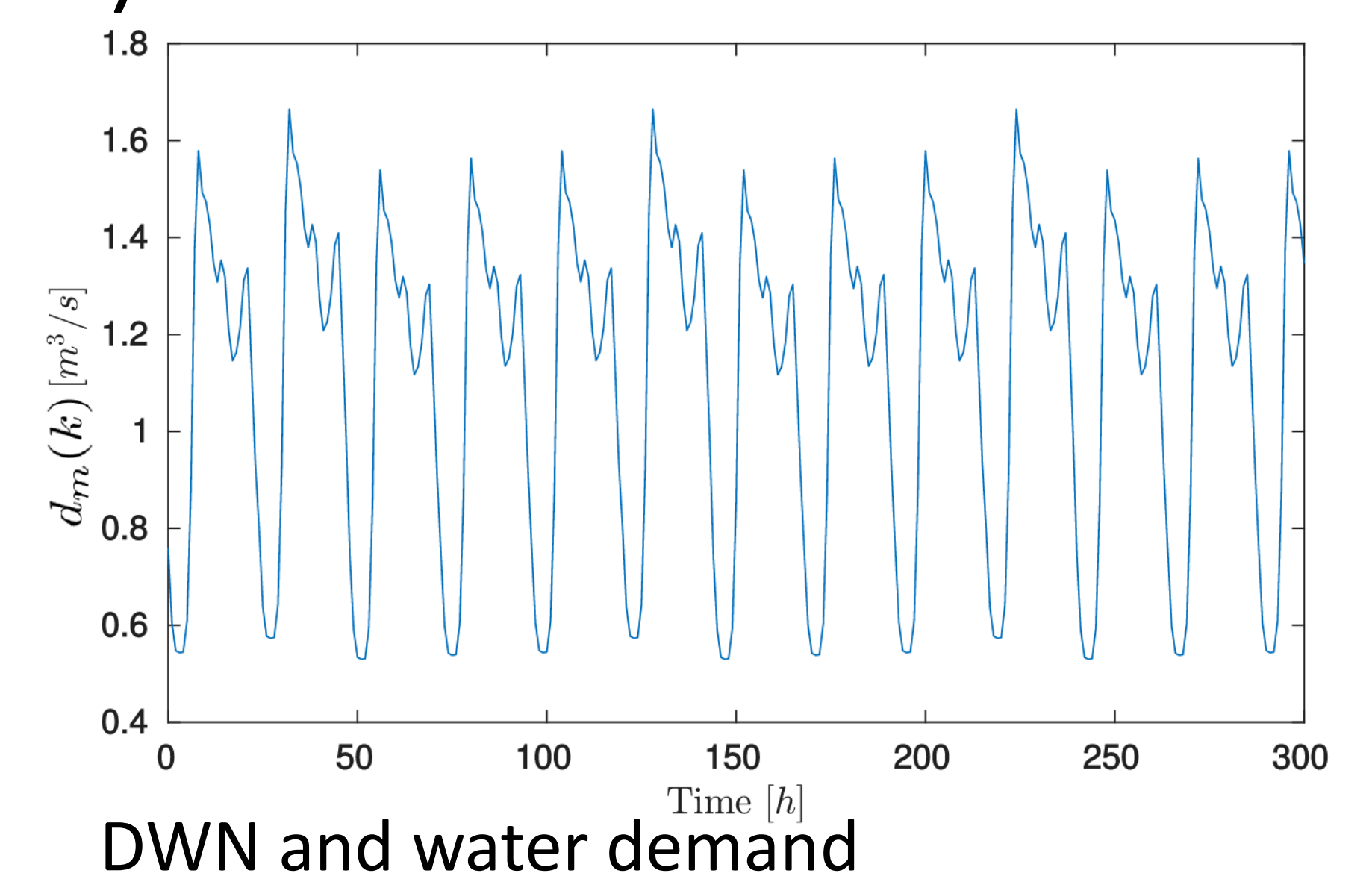
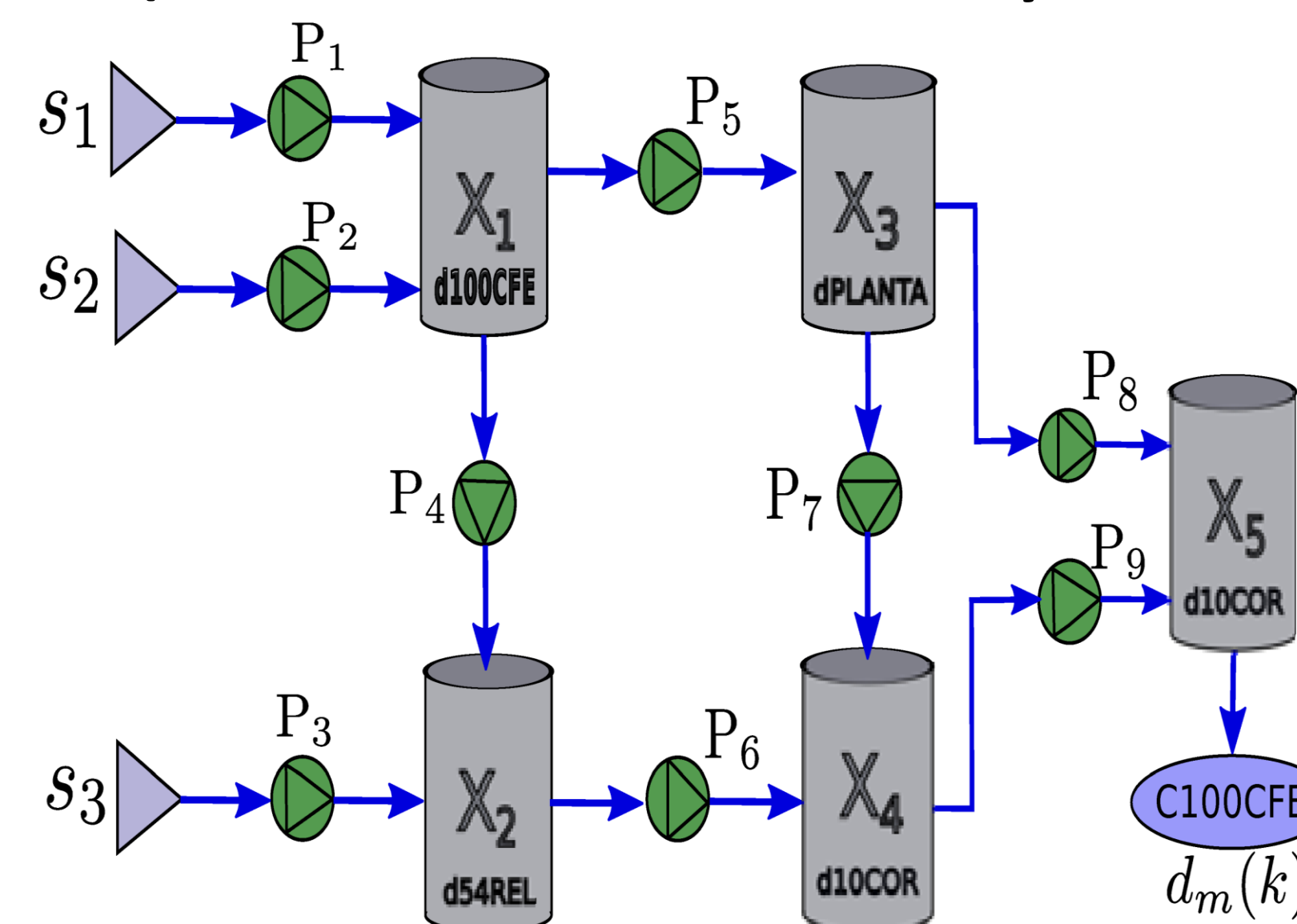

MPC weight evolutions

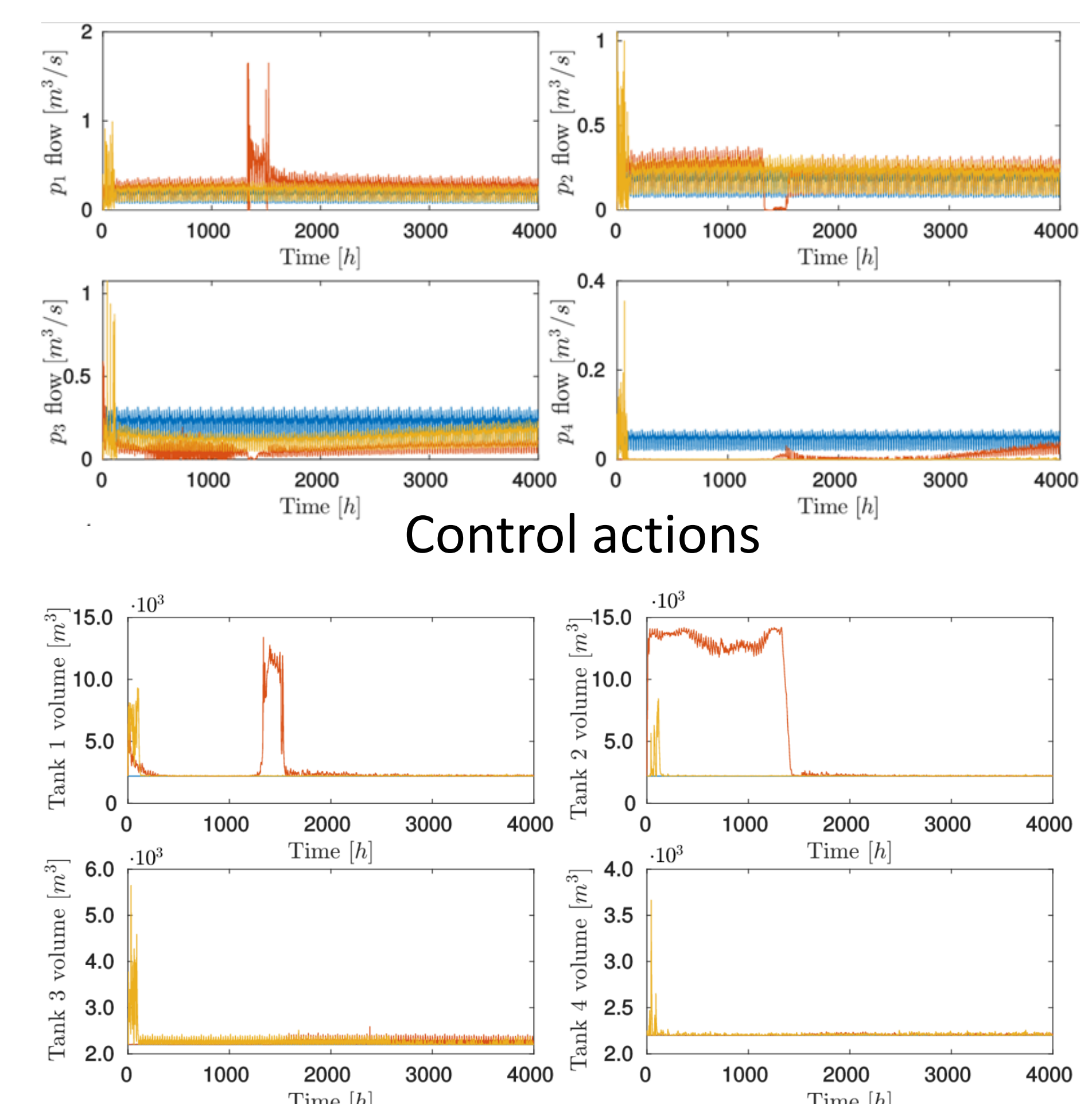

Tank volumes

## Acknowledgments and References

This work has been funded by the Spanish Ministry of Science and Technology through the projects CICYT HARCRIcs (ref. DPI2014-58104-R), CICYT SCAV (ref. DPI2017-88403-R), and by the DGR of Generalitat de Catalunya (SAC group Ref. 2017/SGR/482).

[1] Salazar, J. C., Weber, P., Nejari, F., Sarrate, R., & Theilliol, D. (2017). System reliability aware model predictive control framework. Reliability Engineering & System Safety, 167, 663 - 672.